

Sealing Solutions for Sulzer AHLSTAR^{UP} Series



Safematic™ Type JCS1, JCS1F and JCS2P

Safeseal Type JCS1

Advanced design, good technical solutions

Typical applications

Safeseal Type JCS1 is a rugged, pump integrated single seal designed for clean and lubricating fluids such as water, oils, solvents and low consistency paper stocks. Type JCS1 seal is designed especially for Sulzer AHLSTAR^{UP} pump Series. Type JCS1 seal is easy to install from the impeller side. Type JCS1 is very advanced in its technical capabilities including a patented drive mechanism for seal faces and self aligning, elastically mounted thrust ring.

Features and benefits

1. Balanced design provides undisturbed operation even with sudden pressure shocks.
2. Single spring on atmospheric side located in the stationary part of the seal. Material is corrosion resistant. Shaft misalignment does not pulsate the spring nor wear out the O-ring.
3. SiC/Carbon or SiC/SiC seal faces as standard materials.
4. No measurements required for installation. Easy installation reduces risk of human error.

5. Seal installation does not require back plate removal and the seal is fastened with one bolt which guarantees fast, trouble free installation.
6. Torque transmission with super elastic devices combined with no drive pins at seals faces. Seal faces do not crack at start-up.



Technical specifications

Temperature	194°F/90°C max
Stuffing box pressure	Up to 232 psig/16 barg
Speed	Up to 4,000 fpm/20 m·s ⁻¹

Materials

Seal faces	SiC/Carbon or SiC/SiC
O-rings	PTFE EPDM Viton®
Metals	Standard materials EN 1.4436/1.4460 (AISI 316/329)
Spring	Inconell X-750

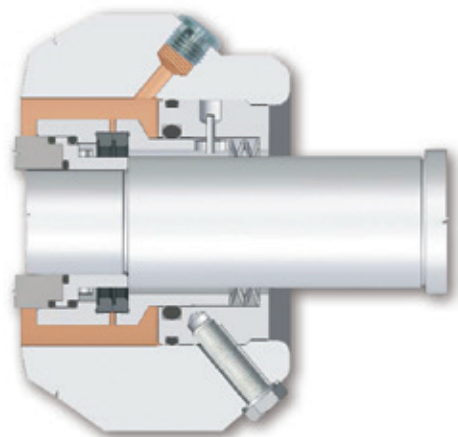

Safeseal Type JCS1F

A reliable seal for demanding conditions
with product recirculation API plan 11 or external water flush

Typical applications

Type JCS1F single seal operates on API plan 11 for hot water applications or on a continuous external water flush principle when needed. It is designed for demanding applications where clean water flush lubricates seal faces. Typical low solids applications include hot water or paper stock pumps at pulp mill washing and screening facilities.

Utilizes the same design features and principles as Type JCS1 seal described earlier.

Pressurized continuous water flush through restricted throttle design into the process provides clean lubrication for the seal faces. This set up also eliminates the possible dry run during the pump start-up.



Technical specifications

Temperature	250°F/120°C max
Stuffing box pressure	Up to 232 psig/16 barg
Speed	Up to 4,000 fpm/20 m·s ⁻¹

Materials

Seal faces	SiC/Carbon or SiC/SiC
O-rings	PTFE EPDM Viton®
Metals	Standard materials EN 1.4436/1.4460 (AISI 316/329)
Spring	Inconel X-750

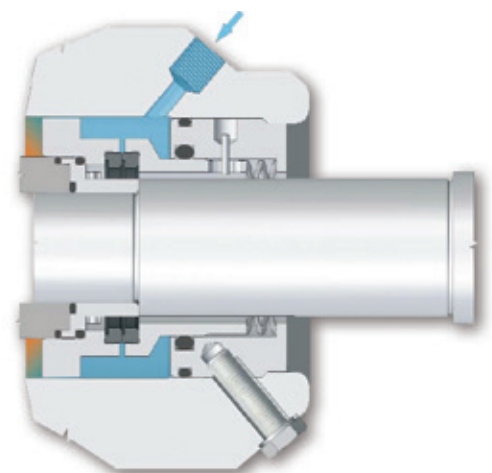

Safeseal Type JCS2P

Double-balanced design, ultimate reliability

Typical applications

The double-balanced design of Safeseal Type JCS2P ensures reliable and long-lasting operation under the most demanding conditions. This seal is typically used in pumps for abrasive and environmentally hazardous liquids in pulp and paper mills. Applications include also demanding services in food, metal and fertilizer processes.

Type JCS2P seal is especially designed for Sulzer AHLSTAR^{UP} pump Series.

Features and benefits

1. Seal utilizes the integrated and advanced Smartflow seal water control technology.
2. More than 90% seal water savings compared to normal flow control system.
3. Single spring located in the stationary part of the seal. Material is corrosion resistant and flushed with seal water.
4. Shaft misalignment does not pulsate the spring nor wear out the O-ring.
5. Heat shrunk SiC/SiC, SiC/Carbon seal faces as standard materials.
6. The piston design of the seal enables large axial movement that does not have impact on spring loading.
7. No measurements required for installation. Easy installation reduces risk of human error.
8. Seal installation does not require back plate removal and the seal is fastened with one bolt which guarantees fast trouble free installation.
9. Torque transmission with super elastic devices combined with no drive pins at seals faces. This eliminates possible start-up failures.
10. Even in standard models, PTFE is used in O-ring positions where they are exposed to the process liquid.
11. The special double-balanced design allows the use of both pressurized and non-pressurized sealant.

Technical specifications

Temperature	356°F/180°C max
Stuffing box pressure	Up to 360 psig/25 barg
Seal water pressure	Up to 220 psig/15 barg
Speed	Up to 4,000 fpm/20 m·s ⁻¹

Materials

Seal faces	SiC/SiC, SiC/SiC
O-rings	PTFE (product side) EPDM, Viton®
Metals	Standard materials EN 1.4436/1.4460 [AISI 316/329]
Spring	Inconel X-750

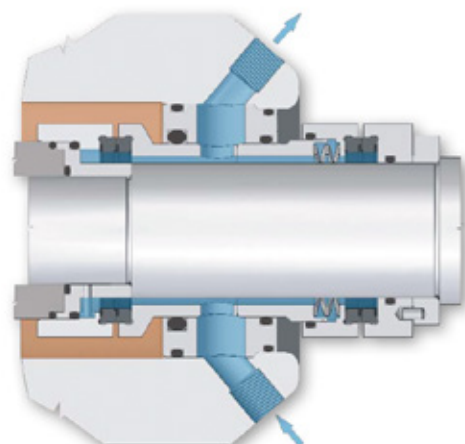

Sealing Solutions for Sulzer AHLSTAR^{UP} Series

Mechanical Sealing Systems

Type JCS Seal Identification Codes

E.g. JCS2P-50-QRMQ-307645

XXX-XX-X₁X₂X₃X₄-XXXXXX

① ② ③ ④

- ① Type of seal JCS1: single seal
 JCS1F: single seal with flush
 JCS2P: double seal

② Shaft diameter: (in, mm)

③ Material codes:

X₁ = inboard faces

Q-SiC/SiC
G-SiC/Carbon

X₂ = wetted metals

R-EN 1.4436/14460 (AISI 316/329)
X-SAF 2205 Duplex
X-SAF 2507 Super duplex
X-654 SMO

X₃ = elastomers

M-PTFE
E-EPDM
V-Viton®
X-Other

X₄ = outboard faces

Q-SiC/SiC
G-SiC/Carbon
O-Single seal

④ Assembly drawing number

John Crane has a comprehensive network of highly trained representatives, distributors, and installation and maintenance personnel. Contact your local John Crane sales office for more information.

John Crane Safematic Seal Support Systems

Seal water filtering, control and monitoring

John Crane's Safematic systems offer a range of seal water filtering, control and monitoring solutions which increase operational reliability, improve plant availability and deliver greater competitiveness for the end user.



Seal water functions

In today's process industries, seal water is often used in conjunction with packing and mechanical seals to both cool and lubricate while ensuring that suspended particles do not hamper sealing effectiveness.

Each seal type has specific seal water flow and pressure requirements. Exceeding these requirements produces no benefits yet greatly increases both water consumption and associated filtration and treatment costs.

Smartflow

Intelligent seal water control

Environmental issues and economic factors are driving a growing demand for reduced seal water consumption and lower sealing costs. With this in mind, John Crane Safematic introduced Smartflow - an intelligent control system that provides water only when it is actually required to cool the seal. The system can deliver seal water savings of up to 97 percent compared to a flow meter controlled alternative.

**Achieves 90% reduction
in water consumption without
limiting seal performance**

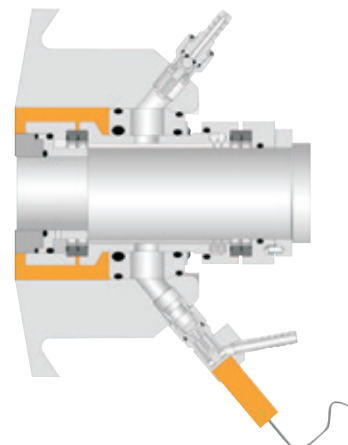

John Crane Safematic Seal Support Systems

Optimize seal operation and performance

Safeunit Ultima

Optimizes seal performance in extreme conditions

Specially designed to control seal water flow and pressure in a wide range of extreme conditions, John Crane's Safeunit Ultima increases the reliability of seals in pumps and process machinery while reducing seal water consumption by up to 80 percent. It is intended for use in harsh operating environments where high temperature, high pressure and chemically aggressive elements are present. This makes it ideal for pulp, paper and chemical industry applications, plus a wide variety of mining and general industrial uses.

The easy-to-install Safeunit Ultima controls and monitors seal water flow and pressure, while also drastically reducing overall consumption levels. Sealing reliability is increased and equipment uptime is extended, while shutdown time and maintenance costs are reduced.

A reliable method of optimizing sealing performance



Safesiphon 10

External reservoir for seal barrier

Safesiphon is designed to provide lubrication and cooling for dual mechanical seals in wide range of industries. Creating the correct working environment can significantly improve seal life savings by reducing maintenance and replacement costs. The natural convection (thermosiphon) effect ensures the mechanical seal is kept cool and lubricated. Installation is fast and easy to do on-site.





YOUR NAME IS HOW WE MAKE OURS



□□□□



Global Service Network

- » Over 200 facilities in more than 50 countries
- » Close proximity to customers' operations
- » Local service and expert global support

North America

United States of America
Tel: 1-847-967-2400

Europe

United Kingdom
Tel: 44-1753-224000

Latin America

Brazil
Tel: 55-11-3371-2500

Middle East & Africa

United Arab Emirates
Tel: 971-481-27800

Asia Pacific

Singapore
Tel: 65-6518-1800



If the products featured will be used in a potentially dangerous and/or hazardous process, your John Crane representative should be consulted prior to their selection and use. In the interest of continuous development, John Crane companies reserve the right to alter designs and specifications without prior notice. It is dangerous to smoke while handling products made of PTFE. Old and new PTFE products must not be incinerated. ISO 9001 and ISO 14001 Certified, details available on request.